



Vogel's Compose[®]



E-SERIES



Q-SERIES



D-SERIES

FURNITURE

BROCHURE

2008/2009



The birth of the Vogel's Compose® adaptable cabinets

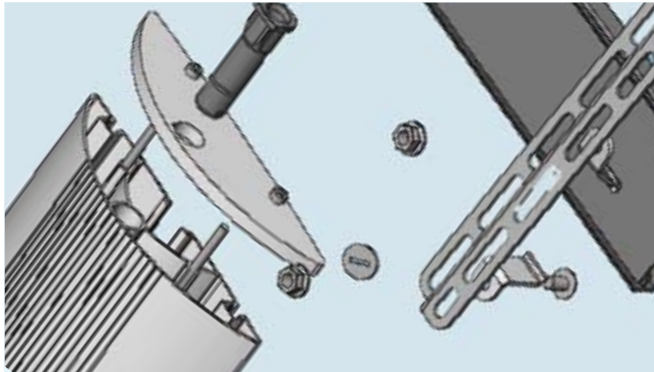

CAD models, mockups and prototypes are made to thoroughly test every aspect of the design



EUROPEAN DESIGN BY VOGEL'S

Want to get more out of your entertainment equipment? Vogel's can help. For years, we've been creating outstanding custom furniture that is designed especially to support and enhance flatscreen TVs, Hi-Fi and audio visual components. Our furniture range is complementary to Vogel's sophisticated range of mounting solutions.

Designed to entertain you

At Vogel's, we have long experience in designing wall mount and furniture concepts that meet the specific requirements of home entertainment equipment. In-house product design, development and engineering are key strategic focal points of our company and we continue to invest heavily in these areas. This has produced a steady stream of innovative concepts and products. We were one of the first to design furniture to support flatscreen TVs. And the elegant Vogel's Compose® flexible modules and adaptable cabinets can be completed with manual and remote controlled flatscreen TV adapters.

We keep our pulse on market developments

Vogel's has a strong marketing department that has a close relationship with our business partners and end customers. They help keep us up-to-date on the latest developments and trends in our markets. In addition, we carry out independent research and visit all relevant trade shows and events to identify new market opportunities. This provides valuable input for our strategic product decisions.

Dedicated industrial design department

Over the last 35 years, our large team of industrial designers and engineers has built up highly specialised knowledge about consumer preferences, materials, functional requirements, ergonomics, and manufacturing processes for designing support products. Our experts provide valuable technical input on the feasibility of new designs before starting a project. This expertise helps us find new ways of doing things and helps us come up with the most creative concepts for new products.

Designed for entertainment

In the end, the mark of a good design is how well it works. Our furniture is designed to give the best solutions for entertainment equipment. Innovative, universally suitable, trendsetting, highly functional and crafted from the finest quality materials. That's the mark of an expert. That's the mark of Vogel's.

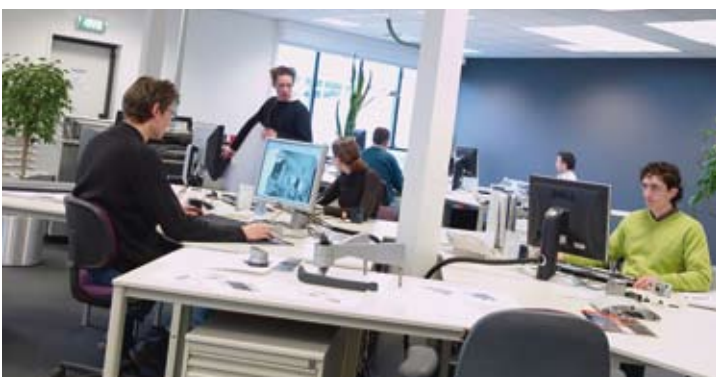

Vogel's industrial designers and engineers each contribute a different perspective and skill to come up with the most innovative solution

QUALITY – FROM START TO FINISH

Vogel's products are built to exact specifications from the most high quality, longlasting materials available. We offer a broad assortment of furniture and stands in virtually any material or style, including glass, wood and aluminium. Models are available with or without a built-in support.

Extra options

Many extra options are available, including additional colour and/or glass combinations, wheels and an LCD adapter to mount an LCD/Plasma flatscreen.



Guarantee

5-year guarantee for all furniture and 2-year guarantee on electronic parts and remote control.

D-SERIES

Aluminium and glass

These models combine solid steel and high-grade polished aluminium alloy frames with crystallite safety glass to create a modern and open look. The transparent topplate and shelves are made of highly polished glass with rounded corners and are completely flat to provide more room for equipment. The topplate is securely and elegantly sealed with UV glue. Each topplate can hold up to 90 kg / 198 lbs of weight.

Q-SERIES

Wood and glass

This line is constructed of high quality MDF with a high gloss finish. The solid construction provides stable support for the largest TV screens and A/V equipment. A variety of colours and finishes are available to fit any interior or style. The self closing drawers offers space for CDs, DVDs and remote controls.



EMO®



Electronic Motion (EMO)

Remote controlled products for easily turning your flatscreen TV to the optimal viewing position.

VOGEL'S COMPOSE®



Walnut



Wengé

Q-SERIES



High gloss black



White



Silver

D-SERIES



Universal mounting

Universal adapter for flatscreen mounting.



Crystallite safety glass

Crystallite, tempered safety glass with UV-bonding.



Integrated CIS®

All cables cleverly concealed and guided by Vogel's unique Cable Inlay System (CIS).



Black or clear glass

Black silkscreen or clear crystallite safety glass is available.

VOGEL'S COMPOSE®

AV FURNITURE



Maximum choice – now and in the future

When it comes to entertainment equipment furniture, today's consumers want great functionality and an appealing design that blends well into their interior. Vogel's new Compose system meets all these criteria and more, featuring streamlined, connectable products that fit seamlessly together in terms of design and finishing. What's more, this unique system can actually adapt and grow to meet changing needs, for instance when new audio/video equipment or a larger LCD/Plasma screen is purchased. The Compose line gives consumers maximum choice, allowing them to effectively organise their entertainment equipment exactly the way they want – today & tomorrow.

FLEXIBLE

Flexible furniture

With Compose, consumers can combine one or more modules and furniture units to create their perfect entertainment platform. Modules can be placed on the floor, but also hung on the wall to create a spacious, floating effect.

The special LCD/Plasma accessory (optional) makes it possible to turn the screen to achieve the optimum viewing angle. And when AV modules are placed vertically, they can also easily accommodate PCs, game consoles and more. Compose is really an all-round multi-media entertainment solution!



Guarantee

5-year guarantee for all furniture



ADAPTABLE

Floor and wall furniture

The Vogel's Compose® floor and wall furniture expands consumers' options even further, allowing them to adapt the width of the entertainment unit from 100cm up to 140cm to exactly match the size of their LCD or plasma screen.



LCD/Plasma accessory

The manual adapter module makes it possible to turn the screen up to 30° left and right, to achieve the optimal viewing angle. Even more convenient is the electronic module which allows the consumer to turn the screen via remote control from the comfort of their chair.



SMART

Clever use of space



Colours

Consumers even have a choice in finishes for the high-quality panels – they are available in both trendy Walnut and exotic Wenge.

Doors

Infrared-transparent covering on doors enables remote-control operation and allows air ventilation when doors are closed.

Cable Inlay System

Cable Inlay System (CIS®) neatly organises and conceals cables from view.

VOGEL'S COMPOSE®

AV FURNITURE



Basic & AV-modules

Suitable for audio, DVD, PC, projector, game console, LCD/Plasma and DVD equipment

- Modules can be mounted on the wall or placed on the floor (basic module can stand-alone only be mounted on the wall)
- Connectable modules can be installed and combined in variety of ways
- Universal: fit almost all LCD/Plasma screens up to 45 kg / 99 lbs
- Basic module is suitable for screens up to 42 inch. A combination of basic and AV modules together is suitable for screens up to 55 inch / 140 cm
- Transparent, infrared metal covering on doors enables remote-controlled operation and ventilation when doors are closed
- When mounted on the wall, the modules extend slightly forward, creating a unique floating effect
- Both basic and AV module can be seamlessly integrated with Compose furniture units
- Modules can be placed horizontally and vertically (AV module) and modules can be mirrored
- Cable Inlay System (CIS®)
- Basic module can support: 1 AV device, max 10 kg / 22 lbs
- AV module can support: 2 AV devices, max 20 kg / 44 lbs
- Optional: can be combined with CFA 140/CFAE 140 RC to turn from side-to-side
- Easy assembly

For technical specifications, see page 17.



Floor/wall AV module CFM 060



Floor/wall Basic module CFM 105

Floor & Wall furniture

Suitable for audio, DVD and LCD/Plasma equipment

- Designed to be mounted on the wall (CFW 140) or placed on the floor (CFF 140)
- Width of units can be adapted for every screen dimension
- Suitable for screens up to 55 inch / 140 cm or up to 45 kg / 99 lbs
- Can be combined with AV modules and with the manual or remote controlled accessory CFA 140/CFAE 140 RC
- Can support AV devices up to 20 kg (44 lbs) on each side (total 40 kg / 88 lbs)
- Cable Inlay System (CIS®)
- Easy assembly
- A unique line which can actually adapt and grow to meet the consumer's changing needs

LCD / Plasma accessories

Suitable for LCD/Plasma equipment

- Compose Flat Accessory Manually max 140 cm / 55 inch (CFA 140)
- Compose Flat Accessory Electronic max 140 cm / 55 inch (CFAE 140 RC)
- Easily turn it to any viewing perspective (30° each side) manually or by remote control



Wall furniture CFW 140



Floor furniture CFF 140



CFAE 140 RC



CFA 140



TWIST AND TURN

E-SERIES

- Turn function guarantee optimal viewing position
- Sturdy design and construction provides extra stability
- Cable Inlay System (CIS®) to hide unsightly cables
- Easy to assemble
- 5-year guarantee

EXTRA FEATURES EFF 1140 & EFF 1140 RC

- Universal – complies with VESA MIS-F or 670,510
- One shelf included. One additional shelf can be ordered (EFA 0040 / EFA 0040 Black)
Supports a maximum of 2 (max 20 kg together)
- Also available in Black

For technical specifications see page 18.



 EFFE 1140 RC – Silver/Black



 EFTE 2240 RC – Silver



 EFTE 2265 RC – Silver



EFF 1140 – Black



Cable Inlay System (CIS)

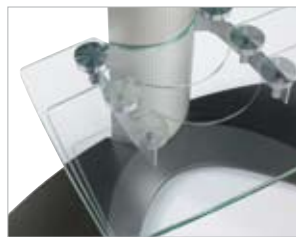

Adjustable in depth

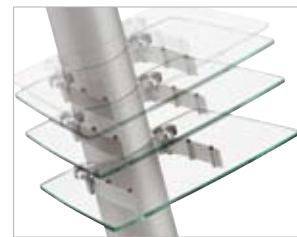

Adjustable in height

ELECTRONIC MOTION (EMO®)



EFFE 1140 RC, EFTE 2240 RC & EFTE 2265 RC

- Easily turn to the optimal viewing position via remote control (max. 60 degrees)
- Universal - complies with VESA MIS-F 670, 510
- Auto home function returns stand to original position
- Universal - fits most flatscreen TVs from 25" up to 42" (max 45 kg) or VESA MIS-F 570, 360 (EFTE 2240 RC)



SHEER STYLE

D-SERIES

- Crystallite tempered safety glass with UV bonding
- High-grade polished aluminium
- Holds up to 4 pieces of A/V equipment
- Max. weight topplate: 60 kg / 132 lbs
- Cable Inlay System (CIS®) to hide unsightly cables
- Easy to assemble
- 5-year guarantee

EXTRA FEATURES DFP 2105 & DFP 2145

- Universal adapter supports all flatscreens up to 50"
- Universal - complies with VESA MIS-F 670,510
- Adapter supports a maximum weight of 70 kg / 154 lbs
- Easily turn it to optimal viewing perspective (max. 45°)

For technical specifications see page 19.



DFP 2145 - Flatscreen mounting



DFP 2105 - Flatscreen mounting



DFP 105 - Flatscreen placement



DFP 88 - Flatscreen placement



DTV 80 / DTV 90 / DTV 110 - Flatscreen placement



DAU 065 - Audio / DVD placement



Universal adapter for flatscreen mounting

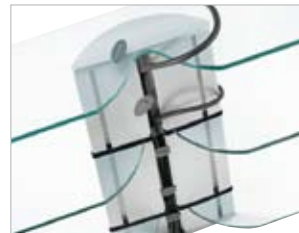

Integrated CIS



UV-bonding

FLATSCREEN MOUNTING

In this model, the Perugia Column is a sleek support for your LCD/Plasma screen TV. Mount your flatscreen TV directly on the robust column of the DFP 2105 and DFP 2145 for extra security and stability. You can easily turn it to any viewing perspective (max. 45°).



BASIC & STYLISH

B-SERIES

- Crystallite tempered safety glass with UV bonding
- Silver painted steel tubes
- Cable Rings
- Shelves for A/V equipment
- Available in clear and black glass
- BFP 90 & BFP 110 equipped with 38 mm tubes
- BFP 290 & BFP 2110 equipped with 60 mm tubes
- Easy to assemble
- 5-year guarantee

For technical specifications see page 20.



BFP 2110 - Black glass



BFP 290 - Clear glass
60 mm tubes



BFP 90 - Clear glass
38 mm tubes



UV-bonding

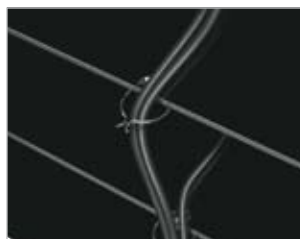

Cable rings

HIGH GLOSS

Q 7000-SERIES & QFF 95

- Crystallite tempered safety glass
- Self closing drawer for additional storage
- Side cupboards with doorstop
- 2 Adjustable glass shelves
- Hidden wheels
- Available in High Gloss Black, White and Silver (QFF 95 only in Silver)
- Holds up to 4 pieces of A/V equipment
- Cable Inlay System (CIS®) to hide unsightly cables
- Completely assembled
- 5-year guarantee

EXTRA FEATURES QFF 95

- Universal – complies with VESA MIS-F, 930, 500 (max. 42" screen), max 70 kg / lbs
- Stable design and construction provides extra stability
- Crystallite, tempered sprayed safety glass
- Glass shelf for audio/video equipment
- Easy assembly
- 5-year guarantee

For technical specifications see page 21.



Q 7120 - High gloss black



QFF 95 - Silver



Q 7068 - High gloss black



Q 7087 - Silver



Q 7077 - White



Side cupboards



Door stop



Self-closing drawer

SLEEK VIEW

Q 6000-SERIES

- Side cupboards for CDs & DVDs with door stops for smooth closing
- Self-closing drawer
- Crystallite tempered safety glass
- Double Cable Inlay System (CIS®) to hide unsightly cables
- Cupboard rests on hidden wheels
- Available in High gloss black, White and Silver*
- Includes 1 shelf (max. 40 kg / 88 lbs)
- Completely assembled
- 5-year guarantee

EXTRA FEATURES Q 6220 & Q 6250

- Perugia Column provides secure mounting for your flatscreen TV
- Easily turn TV mount to optimal viewing perspective (max. 45°)
- Universal - complies with VESA MIS-F 670,510

* Q 6220 and Q 6250 High gloss black models come with (floating) glass plate on top.
Q 6220 and Q 6250 White and Silver models do not have a glass plate on top.

For technical specifications see page 22.



Q 6150 Silver - Direct placement



Q 6220 White - Flatscreen mounting



Self-closing drawer



Side cupboards



Cable Inlay System (CIS)



Universal adapter flatscreen mounting



Q 6250 Black – Flatscreen mounting

FLATSCREEN MOUNTING

In this model, the Perugia Column is a sleek support for your LCD/Plasma screen TV. Mount your flatscreen TV directly on the robust column of the Q 6220 and Q 6250 for extra security and stability. You can easily turn it to any viewing perspective (max. 45°).

































DIRECT PLACEMENT

Take your LCD/Plasma screen out of the box and set it right on top of the Q 6120 and Q 6150 models. Each has a sturdy top shelf that is specially designed to securely support flatscreen TVs. These units can be quickly assembled and look elegant and stylish.



FURNITURE AND STANDS OVERVIEW

FOR ANY DESIRED STYLE AND STORAGE NEED

 Max.	B-SERIES, D-SERIES & E-SERIES		Q-SERIES	
	Steel / Glass	Aluminium / Glass	Wood / Glass	
	Direct placement	Flatscreen mounting	Direct placement	Flatscreen mounting
72 cm / 28"	DTV 80		Q 7077 ²	
82 cm / 32"	BFP 90 ¹ / BFP 290 ¹ / DFP 88 ¹ / DTV 90 ¹		Q 7087 ²	
103 cm / 40"		EFT 2240 / EFTE 2240 RC ³		
107 cm / 42"	BFP 110 ¹ / BFP 2110 ¹ / DFP 105 ¹ / DTV 110 ¹	DFP 2105 / EFF 1140 / EFF 1140 - Black / EFFE 1140 RC ³ / EFFE 1140 RC - Black ³		QFF 95
117 cm / 46"			Q 6120 ² / Q 7120 ²	Q 6220 ²
127 cm / 50"		DFP 2145		Q 6250 ²
152 cm / 60"			Q 6150 ²	
165 cm / 65"		EFT 2265 / EFTE 2265 RC ³		
Audio	DAU 65		Q 7068 ²	
	 DTV 80  BFP 90 ¹	 EFT 2240  EFTE 2240 RC ³	 Q 7077 ²	 QFF 95
	 BFP 290 ¹  DTV 90 ¹	 DFP 2105	 Q 7087 ²	 Q 6220 ²
	 DFP 88 ¹	 EFF 1140  EFF 1140 - Black	 Q 6120 ²	 Q 6250 ²
	 BFP 110 ¹  BFP 2110 ¹	 EFFE 1140 RC ³  EFFE 1140 RC Black ³	 Q 7120 ²	
	 DTV 110 ¹  DAU 65	 DFP 2145  EFT 2265	 Q 6150 ²	
	 DFP 105 ¹	 EFTE 2265 RC ³	 Q 7068 ²	

¹ Also available in black glass

² All versions are available in High gloss Black, Silver and White.

³ Electronic remote controlled version

At www.flatscreenfitter.com you can find the exact furniture that fits each brand of flatscreen TVs.

SPECIFICATIONS

VOGEL'S COMPOSE®



CFM 060



CFM 105

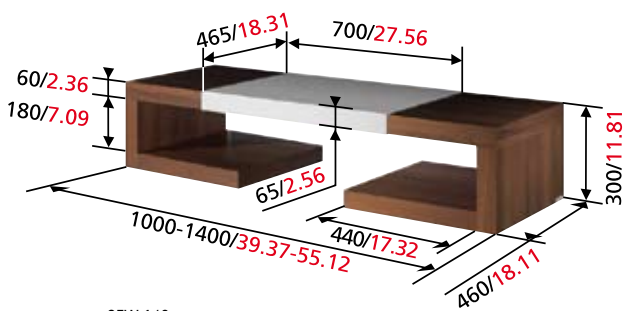

CFW 140

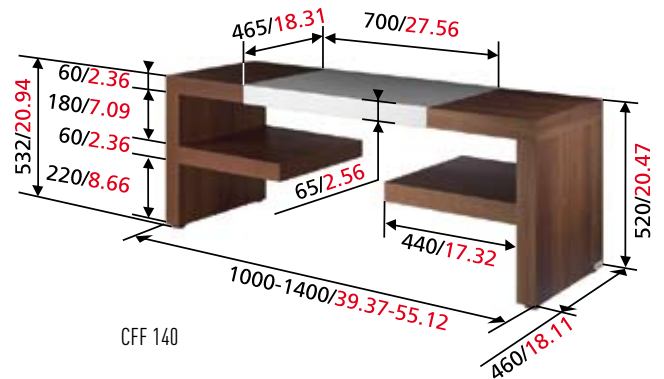

CFF 140

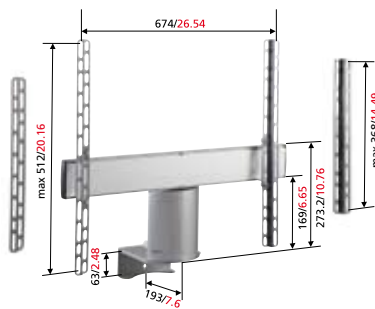

CFA 140

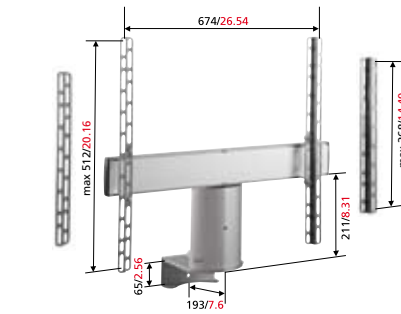

CFAE 140 RC

mm/inch

PRODUCT SPECIFICATIONS

Type nr.	Primary application	Max.	Max. adapter	Max. AV equipment	Pivot Points	VESA	CIS®	Placement	RC incl.	Mirror use	Turnable	Guarantee Yrs	Packaging
CFM 060	LCD/Plasma/DVD/Audio		45 kg / 99 lbs	20 kg / 44 lbs			✓	WN/WE	Wall / Floor	✓		5	Flat packed
CFM 105	LCD/Plasma/DVD/Audio	105 cm / 42" / 140 cm / 55" *	45 kg / 99 lbs	10 kg / 22 lbs			✓	WN/WE	Wall / Floor*	✓		5	Flat packed
CFW 140	LCD/Plasma/DVD/Audio	140 cm / 55"	45 kg / 99 lbs	20 kg / 44 lbs			✓	WN/WE	Wall			5	Flat packed
CFF 140	LCD/Plasma/DVD/Audio	140 cm / 55"	45 kg / 99 lbs	20 kg / 44 lbs			✓	WN/WE	Floor			5	Flat packed
CFA 140	LCD / Plasma	140 cm / 55"	45 kg / 99 lbs		1	MIS-F 670,510		S	CFM 105 / CFW 140 / CFF 140		30° left / right	5	Flat packed
CFAE 140 RC	LCD / Plasma	140 cm / 55 inch	45 kg / 99 lbs		1	MIS-F 670,510	✓	S	CFM 105 / CFW 140 / CFF 140	✓	30° left / right	2	Flat Packed

* in combination with AV module

EAN-CODES

Type nr.	Silver (S)	Walnut (WN)	Wenge (WE)
CFM 060		8712285313127	8712285313141
CFM 105		8712285313165	8712285313189
CFW 140		8712285313240	8712285313264
CFF 140		8712285313288	8712285313301
CFA 140	8712285313226		
CFAE 140 RC	8712285313202		

Visit www.vogels.com for more information.

E-SERIES

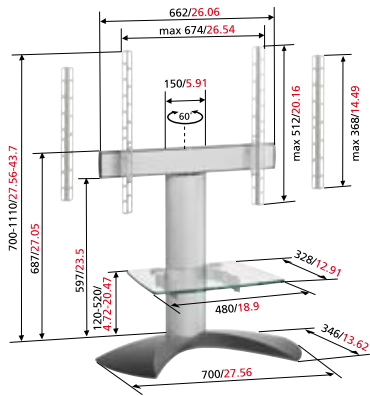

EFF 1140 / EFF 1140 - Black

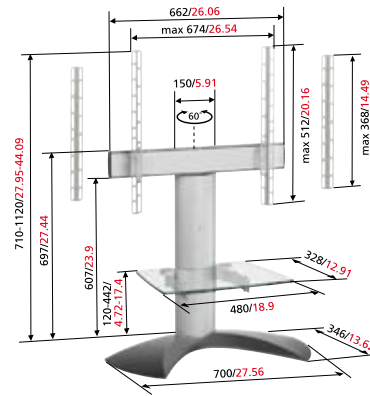

EFFE 1140 RC

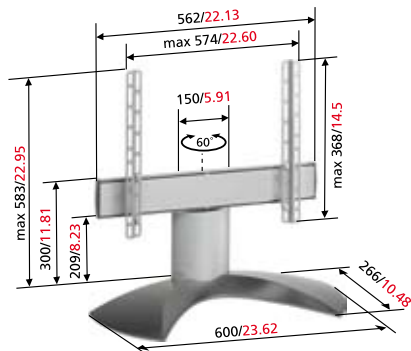

EFT 2240

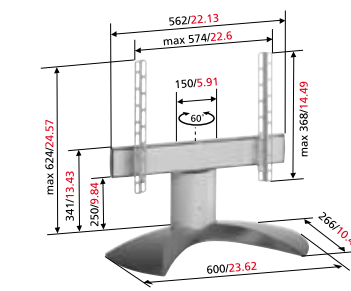

EFTE 2240 RC

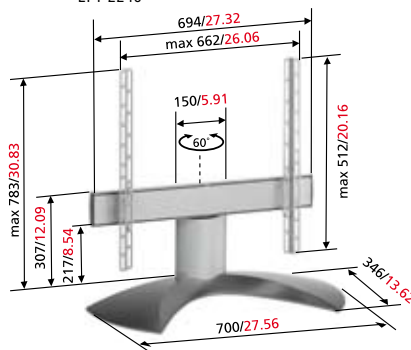

EFT 2265

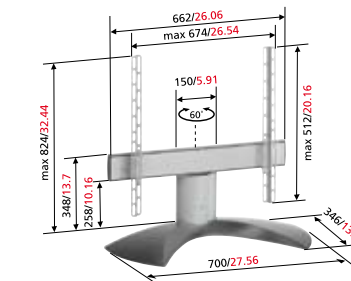

EFTE 2265 RC

mm/inch

PRODUCT SPECIFICATIONS

Type nr.	Primary application	Max.	Max. weight	Max. adapter	Pivot Points	VESA	CIS®	Placement	RC incl.	Turnable	Guarantee Yrs	Packaging
EFF 1140	LCD/Plasma/DVD/Audio	63-107 cm / 25-42"		45 kg / 99 lbs	1	MIS-F 670,510	✓	HGB/S	Floor	60°	5	Flat Packed
EFFE 1140 RC	LCD/Plasma/DVD/Audio	63-103 cm / 25-40"		45 kg / 99 lbs	1	MIS-F 670,510	✓	HGB/S	Floor	60°	2	Flat Packed
EFT 2240	LCD / Plasma	63-103 cm / 25-40"		30 kg / 66 lbs	1	MIS-F 570,360	✓	S	Table	60°	5	Flat Packed
EFTE 2240 RC	LCD / Plasma	63-107 cm / 25-42"		30 kg / 66 lbs	1	MIS-F 570,360	✓	S	Table	60°	2	Flat Packed
EFT 2265	LCD / Plasma	104-165 cm / 41-65"		70 kg / 154 lbs	1	MIS-F 670,510	✓	S	Table	60°	5	Flat Packed
EFTE 2265 RC	LCD / Plasma	104-165 cm / 41-65"		70 kg / 154 lbs	1	MIS-F 670,510	✓	S	Table	60°	2	Flat Packed
EFA 0040	DVD/Audio	Suitable for EFF 1140, EFFE 1140 RC (Max 2)	10 kg / 22 lbs					HGB/S	EFF 1140 / EFFE 1140 RC		5	Flat Packed

EAN-CODES

Type nr.	High Gloss Black (HGB)	Silver (S)
EFF 1140	8712285312663	8712285309328
EFFE 1140 RC	8712285312687	8712285312649
EFT 2240		8712285309281
EFTE 2240 RC		8712285312601
EFT 2265		8712285309304
EFTE 2265 RC		8712285312625
EFA 0040	8712285312700	8712285309427

Visit www.vogels.com for more information.

D-SERIES

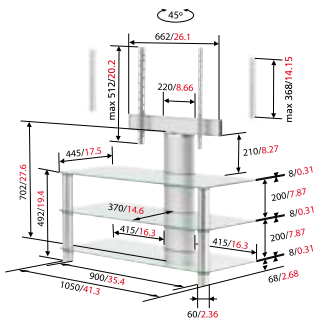

DFP 2105

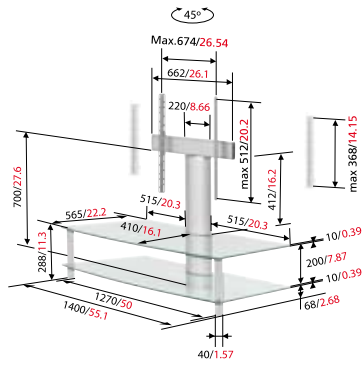

DFP 2145

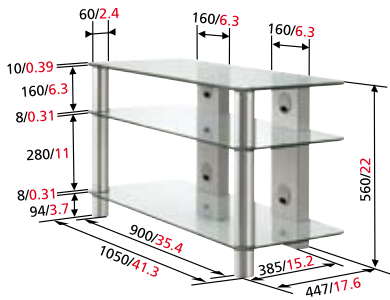

DFP 105

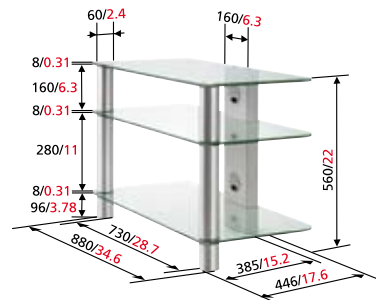

DFP 88

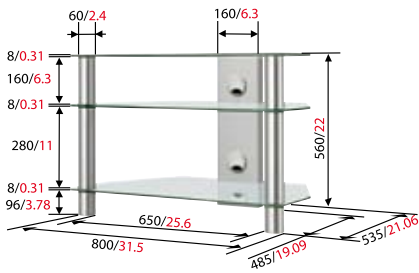

DTV 80

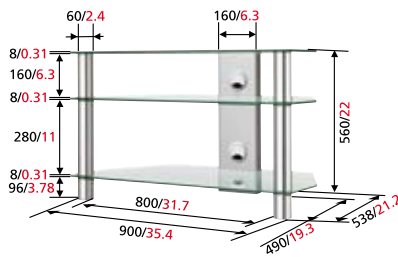

DTV 90

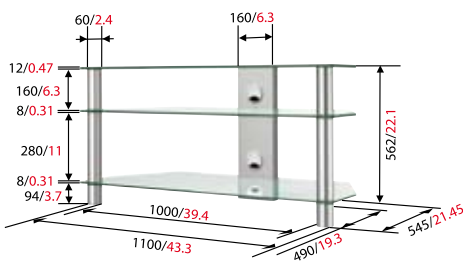

DTV 110

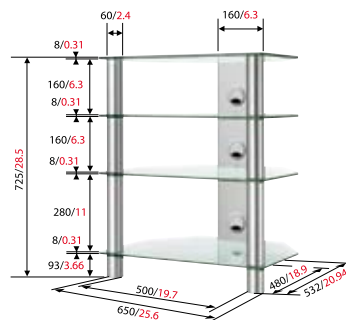

DAV 65

mm/inch

PRODUCT SPECIFICATIONS

Type nr.	Primary application	Max.	Max. topplate	Max. adapter	Max. shelves	VESA	CIS®		Packaging	Clear Glass (CLG)	Black Glass (BG)
DFP 2145	LCD / Plasma / DVD / Audio	127 cm / 50"		70 kg / 154 lbs	60 kg / 132 lbs	MIS-F670,510	✓	CLG	Flat packed	EAN 8712285309588	
DFP 2105	LCD / Plasma / DVD / Audio	107 cm / 42"		70 kg / 154 lbs	60 kg / 132 lbs	MIS-F670,510	✓	CLG	Flat packed	EAN 8712285309564	
DFP 105	LCD / Plasma / DVD / Audio	107 cm / 42"	90 kg / 198 lbs		40 kg / 88 lbs		✓	CLG / BG	Flat packed	EAN 8712285308024	EAN 8712285311222
DFP 88	LCD / DVD / Audio	82 cm / 32"	90 kg / 198 lbs		40 kg / 88 lbs		✓	CLG / BG	Flat packed	EAN 8712285308000	EAN 8712285311208
DTV 110	LCD / Plasma / DVD / Audio	107 cm / 42"	90 kg / 198 lbs		40 kg / 88 lbs		✓	CLG / BG	Flat packed	EAN 8712285307201	EAN 8712285311185
DTV 90	LCD / Plasma / DVD / Audio	82 cm / 32"	90 kg / 198 lbs		40 kg / 88 lbs		✓	CLG / BG	Flat packed	EAN 8712285307188	EAN 8712285311161
DTV 80	LCD / DVD / Audio	72 cm / 28"	90 kg / 198 lbs		40 kg / 88 lbs		✓	CLG	Flat packed	EAN 8712285307164	
DAV 65	DVD / Audio	-	40 kg / 88 lbs		40 kg / 88 lbs		✓	CLG	Flat packed	EAN 8712285307140	

Visit www.vogels.com for more information.

EAN-CODES

B-SERIES

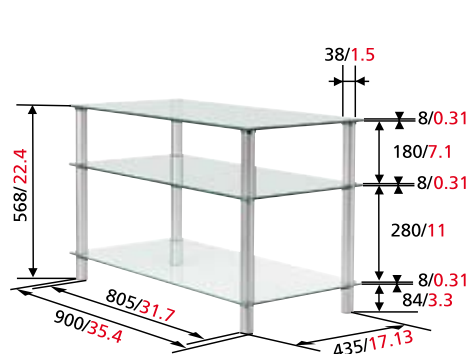

BFP 90

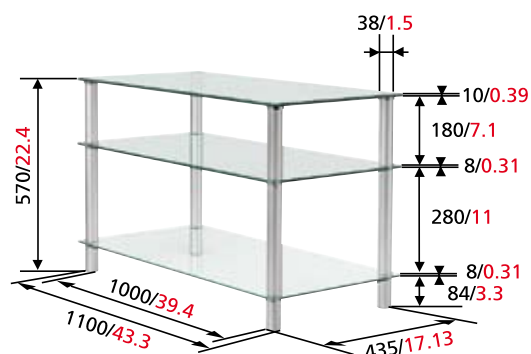

BFP 110

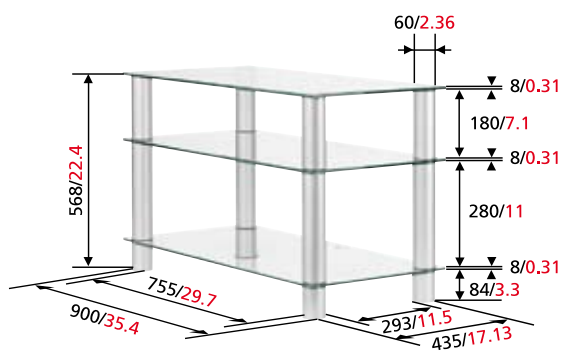

BFP 290

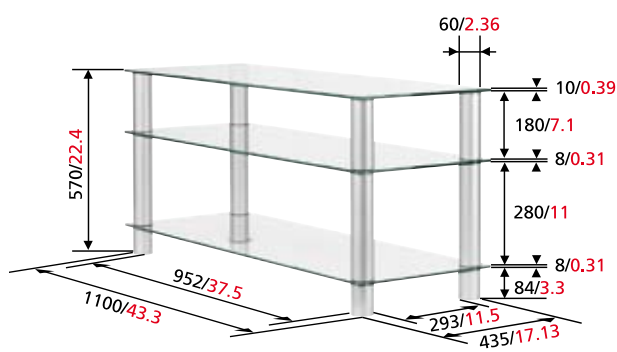

BFP 2110

mm/inch

PRODUCT SPECIFICATIONS

Type nr.	Primary application	Max.	Max. topplate	Max. AV equipment	CIS®		Placement	Guarantee Yrs	Packaging
BFP 110	LCD/Plasma/DVD/Audio	t/m 107 cm / 42"	90 kg / 198 lbs	40 kg / 88 lbs	✓	BG/CLG	Floor	5	Flat Packed
BFP 90	LCD/Plasma/DVD/Audio	t/m 82 cm / 32"	90 kg / 198 lbs	40 kg / 88 lbs	✓	BG/CLG	Floor	5	Flat Packed
BFP 2110	LCD/Plasma/DVD/Audio	t/m 107 cm / 42"	90 kg / 198 lbs	40 kg / 88 lbs	✓	BG/CLG	Floor	5	Flat Packed
BFP 290	LCD/Plasma/DVD/Audio	t/m 82 cm / 32"	90 kg / 198 lbs	40 kg / 88 lbs	✓	BG/CLG	Floor	5	Flat Packed

EAN-CODES

Type nr.	Black Glass (BG)	Clear Glass (CLG)
BFP 110	8712285311147	8712285309106
BFP 90	8712285311123	8712285309083
BFP 2110	8712285312762	8712285312786
BFP 290	8712285312724	8712285312748

Visit www.vogels.com for more information.

Q 7000-SERIES & QFF 95

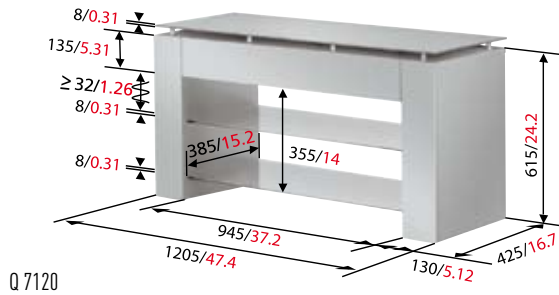

Q 7120

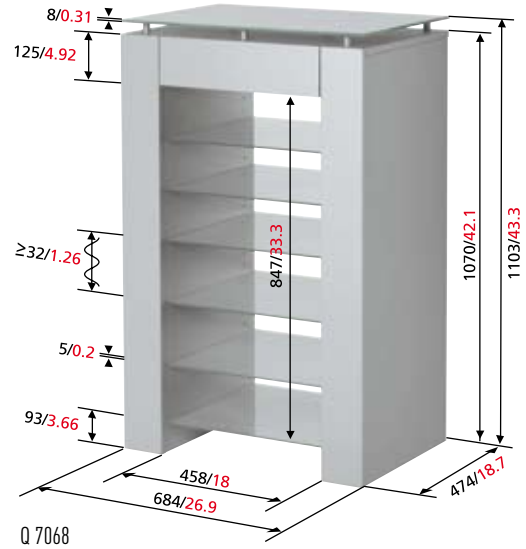

Q 7068

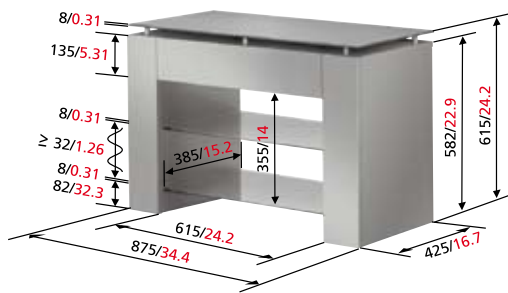

Q 7087

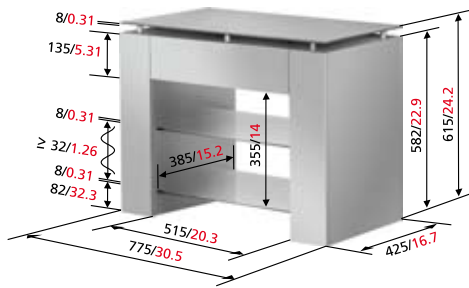

Q 7077

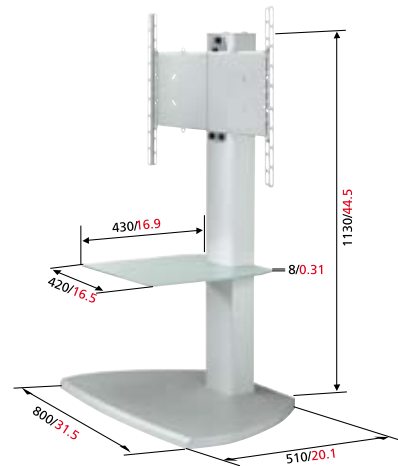

QFF 95

mm/inch

PRODUCT SPECIFICATIONS

Type nr.	Primary application	Max.	Max. topplate	Max. Adapter	Max. AV equipment	VESA	Wheels	Drawer	CIS®	Placement	Guarantee Yrs	Packaging	
Q 7120	LCD/Plasma/DVD/Audio	117 cm / 46"	90 kg / 198 lbs		40 kg / 88 lbs		✓	✓	✓	HGB/S/W	Floor	5	Assembled
Q 7087	LCD/Plasma/DVD/Audio	82 cm / 32"	90 kg / 198 lbs		40 kg / 88 lbs		✓	✓	✓	HGB/S/W	Floor	5	Assembled
Q 7077	LCD/Plasma/DVD/Audio	72 cm / 28"	90 kg / 198 lbs		40 kg / 88 lbs		✓	✓	✓	HGB/S/W	Floor	5	Assembled
Q 7068	DVD/Audio		50 kg / 110 lbs		40 kg / 88 lbs			✓	✓	HGB/S/W	Floor	5	Assembled
QFF 95	LCD/Plasma/DVD/Audio	107 cm / 42"		70 kg / 154 lbs	30 kg / 66 lbs	MIS-F930, 500			✓	S	Floor	5	Flat Packed

EAN-CODES

Type nr.	High Gloss Black (HGB)	Silver (S)	White (W)
Q 7120	8712285309625	8712285309601	8712285311864
Q 7087	8712285310683	8712285311840	8712285310706
Q 7077	8712285310645	8712285310669	8712285311826
Q 7068	8712285310607	8712285310621	8712285311802
QFF 95		8712285310126	

Visit www.vogels.com for more information.

Q 6000-SERIES

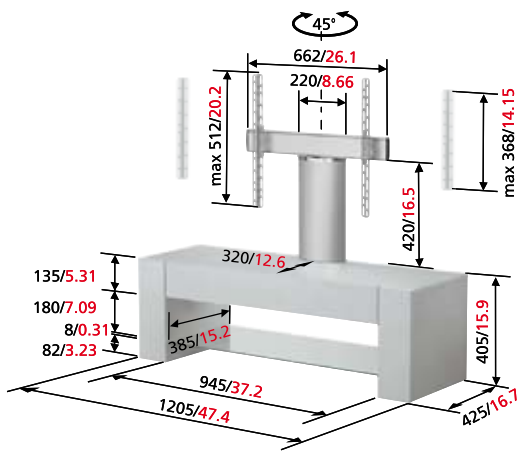

Q 6220

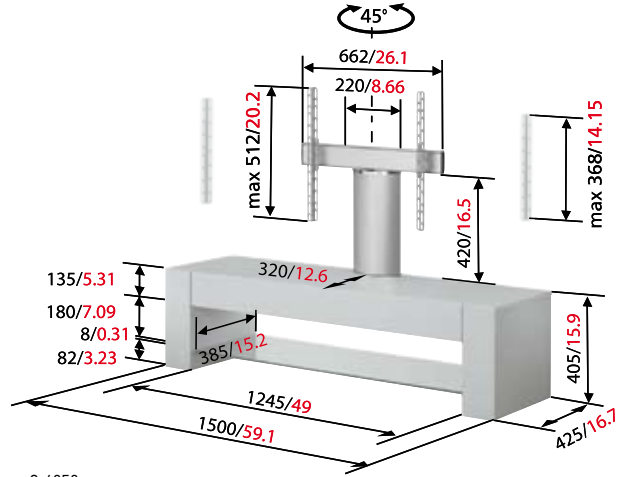

Q 6250

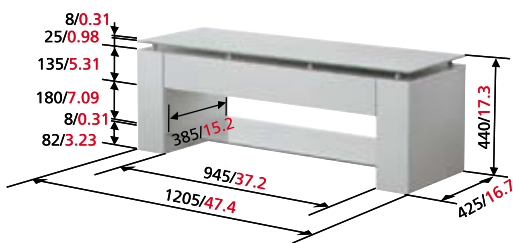

Q 6120

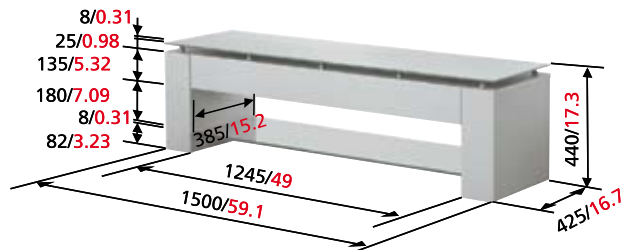

Q 6150

mm/inch

PRODUCT SPECIFICATIONS

Type nr.	Primary application	Max. screen size	Max. topplate	Max. adapter	Max. AV equipment	Pivot Points	VESA	Wheels	Drawer	CIS®	Placement	Turnable	Guarantee Yrs	Packaging	
Q 6250	LCD/Plasma/DVD/Audio	127 cm / 50"		70 kg / 154 lbs	40 kg / 88 lbs	1	MIS-F 670,510	✓	✓	✓	HGB/S/W	Floor	45°	5	Assembled
Q 6220	LCD/Plasma/DVD/Audio	117 cm / 46"		70 kg / 154 lbs	40 kg / 88 lbs	1	MIS-F 670,510	✓	✓	✓	HGB/S/W	Floor	45°	5	Assembled
Q 6150	LCD/Plasma/DVD/Audio	150 cm / 60"	90 kg / 198 lbs		40 kg / 88 lbs			✓	✓	✓	HGB/S/W	Floor		5	Assembled
Q 6120	LCD/Plasma/DVD/Audio	117 cm / 46"	90 kg / 198 lbs		40 kg / 88 lbs			✓	✓	✓	HGB/S/W	Floor		5	Assembled

EAN-CODES

Type nr.	High Gloss Black (HGB)	Silver (S)	White (W)
Q 6250	8712285310560	8712285310584	8715585311789
Q 6220	8712285310522	8712285310546	8712285311756
Q 6150	8712285310485	8715585310508	8712285311741
Q 6120	871228530447	8712285310461	8712285311727

Visit www.vogels.com for more information.

VOGEL'S IMPORTERS

Africa

Country **Importer**
ZA Radionic Distributors Pty Ltd.

Telephone
+27117405573

E-mail
info@radionic.co.za

Website
www.radionic.co.za

Americas

AN Boolchand's Curacao +59994612262
 Boolchand's St Maarten +5995422245
 BR Linear Audio +1155894450
 CA Precor Consumer Electronics +9056606234
 CL Audio plus +5622176466
 MX Embodiment S.A. de C.V. +52556688765
 VZ Electrodomesticos JVG Hogar C.A. +582122868118

boolchandcs@bgate.net
 avinash@boolchands.com
 linearaudio@linearaudio.com.br
 sales@precor.ca
 ac@audioplus.cl
 embodiment_mx@hotmail.com
 cesarj10@cantv.net

www.linearaudio.com.br
 www.precor.ca
 www.audioplus.cl
 www.jvg.com

Asia-Pacific

AU Canohm +61396454700
 HK Soundtronics Limited +85225309939
 IN ARN Systems Put. Ltd. +918041459999
 JP OSM Co. Ltd. +81790645888
 NZ Mayo Group +6494788853
 SG Simple & Pure Solutions Pte. Ltd. +6562344168
 TW Shouyo Electronics Co. Ltd. +886227995586

sales@canohm.com
 info@soundtronics.com.hk
 info@arnsystems.com
 k.kobayashi@osscreen.com
 jim@mayogroup.co.nz
 admin@simplepure.com.sg
 reishi@shouyo.com.tw

www.canohm.com.au
 www.soundtronics.com.hk
 www.arnsystems.com
 www.osscreen.com
 www.mayogroup.co.nz
 www.simplepure.com.sg
 www.shouyo.com.tw

Middle East

AE A&M Trading +97148832401

naser@groupav.com

www.groupav.com

Europe

AM Zigzag +37410545588
 AT H.F. Dollmann +43522342130
 Stefani Elektronik GmbH +437229618710
 AZ Azel Azerbaijan Electronics +99412974040
 BE Lucodex NV +3238447282
 BG Vigo +359 2 9290301
 CH Telion AG +41447321770
 CY MS Electronics +35725580611
 CZ EasyCo s.r.o. +42261224555
 DE Schnepel GmbH & Co KG +49574134610
 DK Aurora Group Denmark A/S +4544858200
 EE Sandman Group +3726512200
 ES ANMI (Andreu & Miriam) SA +34934853932
 FI Aurora Group Finland Oy +358207438060
 FR D.A.M. +33164977400
 GB BBG Distribution Ltd +441923205605
 GE Zakhar LLC +99532355639
 GR Kinotechniki +302109601071
 HR Dacco D.O.O. +38512456666
 TD Elektronika D.O.O. +38512431555
 HU Steelbird +3614637163
 IE Hi Fidelity Marketing +35351853416
 IS Television Centre Ltd. +3545689090
 IT Pozzi Italia s.r.l. +390392785385
 LT Ogmina Ltd. +37052741750
 ACME Computer Components +37037395006
 LU Lucodex NV +3238447282
 LV Latsat Ltd. +3717813311
 MT YAL Home and Electronics +35621419550
 NL Havoned B.V. +31341359050
 NO Aurora Group Norway A/S +4773829445
 PT Videoacústica +351214241770
 PL Arkas Sp. z o.o. +48768711974
 RO VOG-Design Trade S.R.L. +40213121909
 RU Optima Ltd. +74957730553
 SE Aurora Group Sweden AB +46856490850
 SK TT-Thais Trading +4210905429926
 SL Technotop +38615461850
 SR Av Max Group +38132227469
 TR Aztek Teknoloji Ürünleri +902122798889
 UA Dumka +380567782500

shahen@zigzag.am
 info@dollmann.at
 info@stefani-elektronik.at
 newmail@azel.net
 admin@lucodex.be
 contact@vigo-bg.com
 shartmann@telion.ch
 info@mstronics.com
 vogels@easycy.cz
 info@schnepel.com
 info@aurogroup.dk
 info@sandman.ee
 info@anmielectronics.com
 info@aurogroup.fi
 dam@damdiff.com
 info@bbg.eu.com
 zakharllc@gol.ge
 info@kinotechniki.gr
 darko.vekic@dacco.hr
 td-elektronika@zg.tel.hr
 vogels@axelero.hu
 hifidelity@eircom.net
 olafur@sm.is
 commerciale@pozziitalia.it
 e.prateika@ogmina.lt
 audrius.kundelis@acme.lt
 admin@lucodex.be
 latsat@latsat.com
 adriang@onvol.net
 info@havoned.nl
 info@auroragroup.no
 office@videoacustica.pt
 arkas@arkas.pl
 office@vog-design.ro
 info@vogels.ru
 info@auroragroup.se
 info@vogels.sk
 technotop@siol.net
 avmax@pvt.yu
 info@aztekteknoloji.com
 import@dumka.net.ua

www.zigzag.am
 www.stefani-elektronik.at
 www.azel.net
 www.lucodex.be
 www.vigo-bg.com
 www.telion.ch
 www.mstronics.com
 www.vogels.cz
 www.schnepel.com
 www.auroragroup.dk
 www.sandman.ee
 www.anmielectronics.com
 www.auroragroup.fi
 www.bbg.eu.com
 www.kinotechniki.gr
 www.dacco.hr
 www.td-elektronika.hr
 www.vogels.hu
 www.sm.is
 www.pozziitalia.it
 www.ogmina.lt
 www.acc.acme.lt
 www.lucodex.be
 www.latsat.com
 www.yalmalta.com
 www.havoned.nl
 www.auroragroup.no
 www.videoacustica.pt
 www.arkas.pl
 www.vog-design.ro
 www.vogels.ru
 www.auroragroup.se
 www.vogels.sk
 www.aztekteknoloji.com
 www.dumka.net.ua



In 1973 Vogel's, based in the Netherlands, introduced the world's first loudspeaker support. Now, 35 years later Vogel's is recognized worldwide as the industry's expert in the design, placement and manufacturing of mounts and furniture for audio and video equipment. Over the years Vogel's introduced many new and innovative products to the market.

Vogel's Products B.V.
Eindhoven, The Netherlands

