

- EN Mounting instructions
- DE Montageanleitung
- FR Consignes d'installation
- NL Montagevoorschrift
- ES Instrucciones de montaje
- IT Istruzioni di montaggio
- PT Manual de montagem
- EL Οδηγίες συναρμολόγησης
- SV Montageföreskrifter
- PL Instrukcja montażu
- RU Инструкция по сборке и установке
- CZE Návod k montáži
- SK Návod na montáž
- HU Szerelési előírás
- TR Montaj k ilavuzu
- RO Instrucțiuni de montaj
- UK Вказівки по монтажі
- BG Инструкция за монтаж
- JA 設置の説明書
- ZH 装配说明

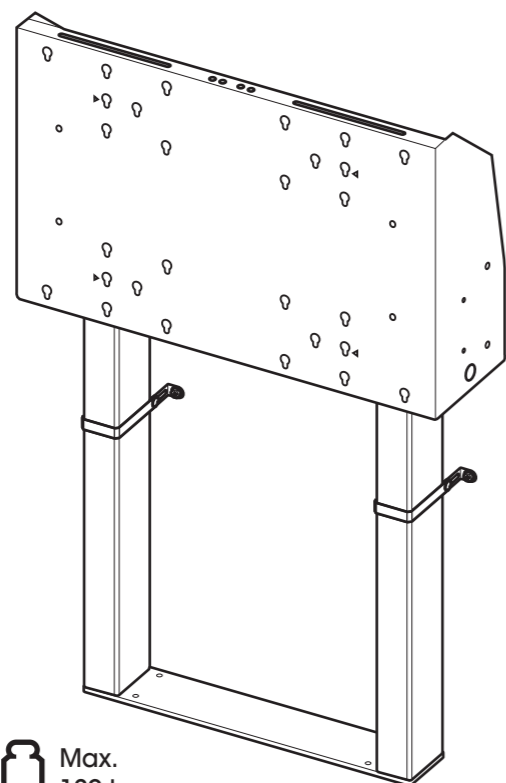

## FLOOR MOUNTED



Max.  
120 kg

(1x) PFI 3062 + (1x) PFFE 7109

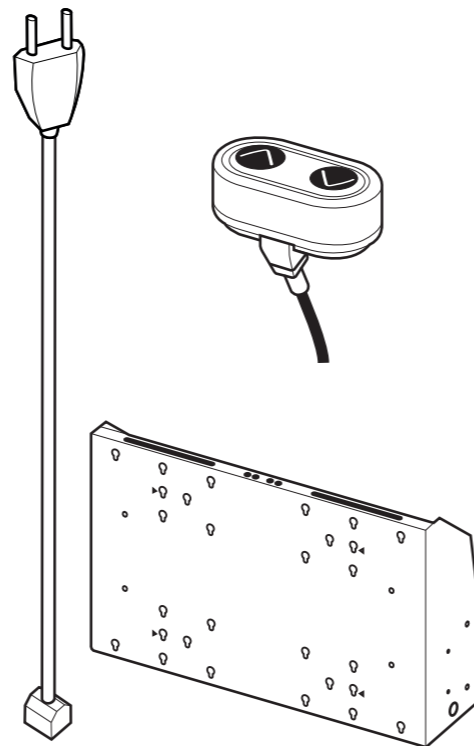

**PFI 3062**

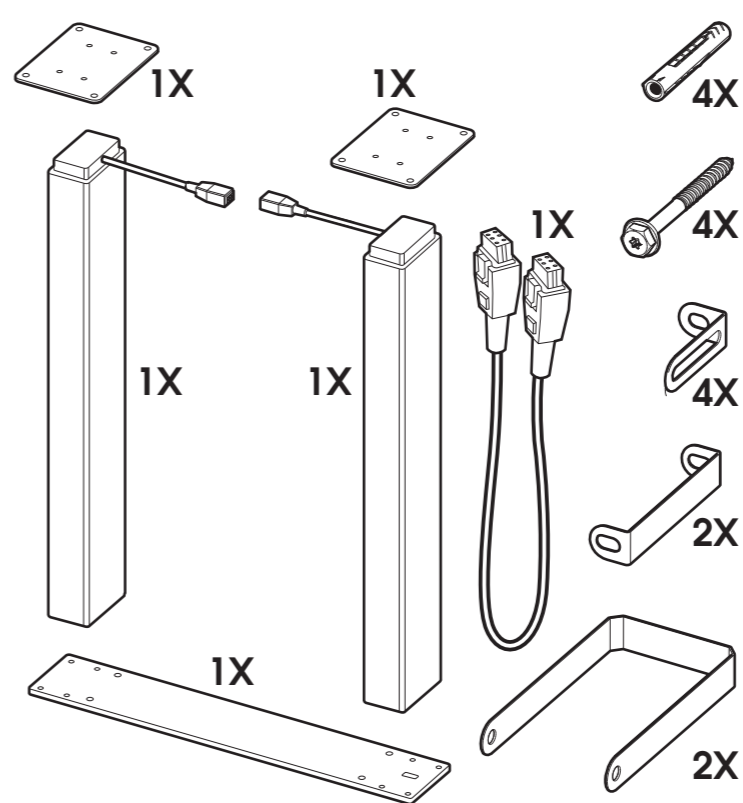

**PFFE 7109**

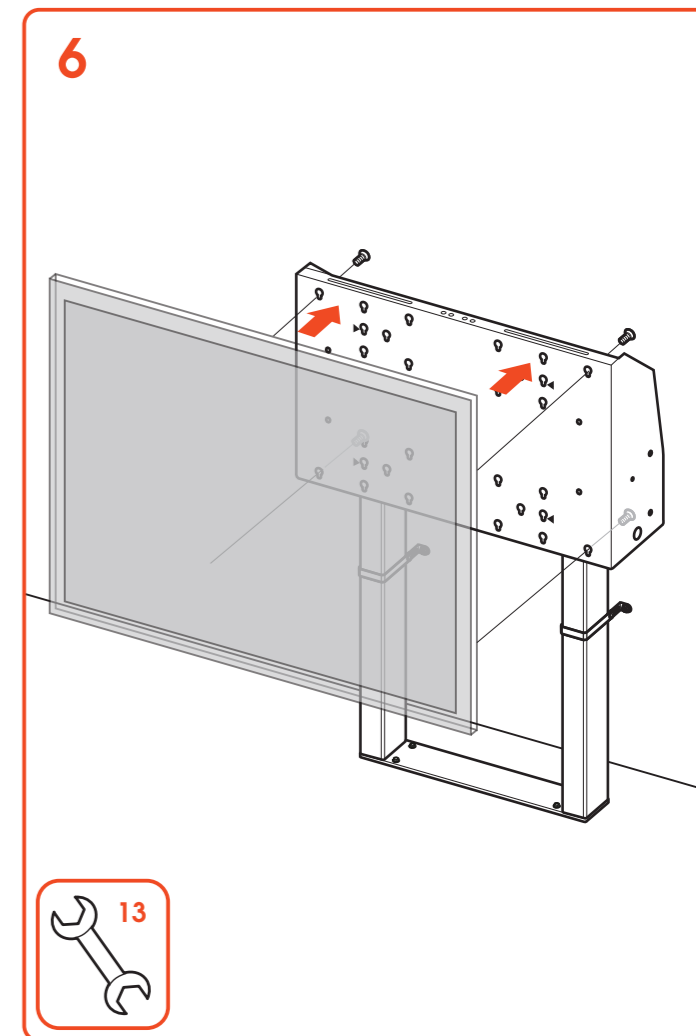
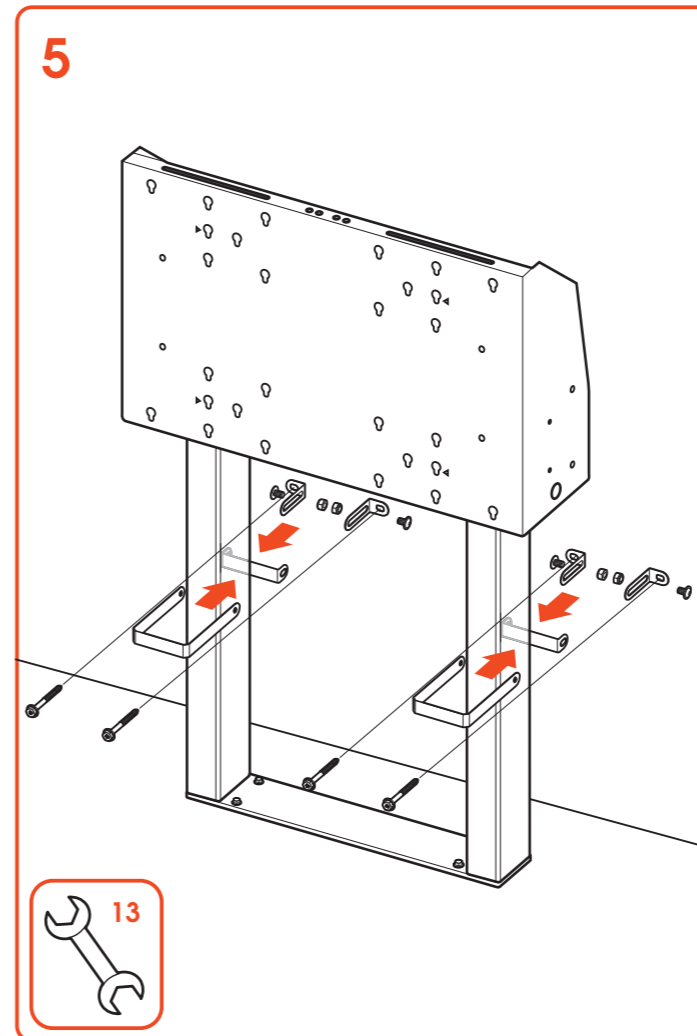
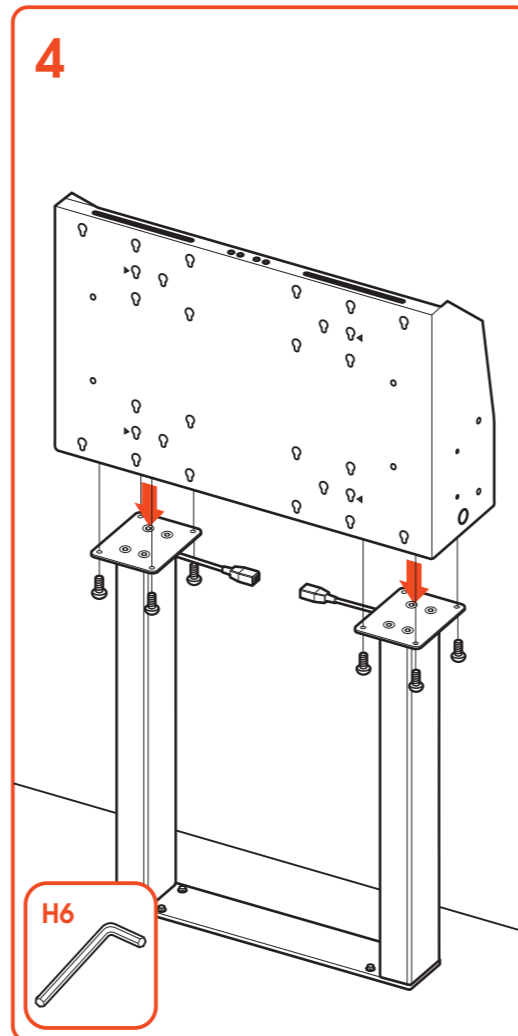
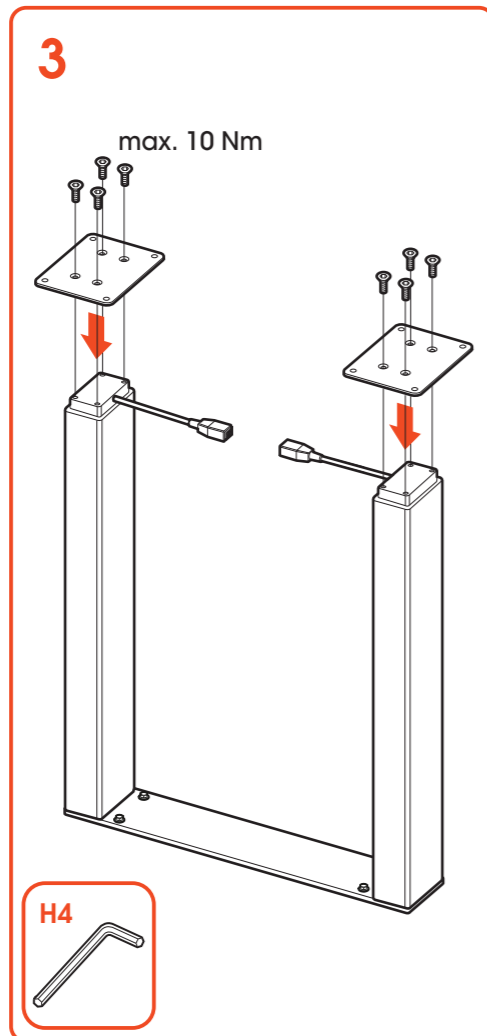
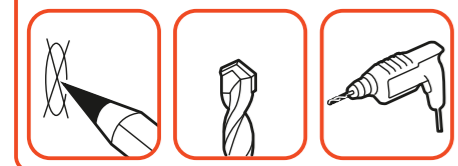
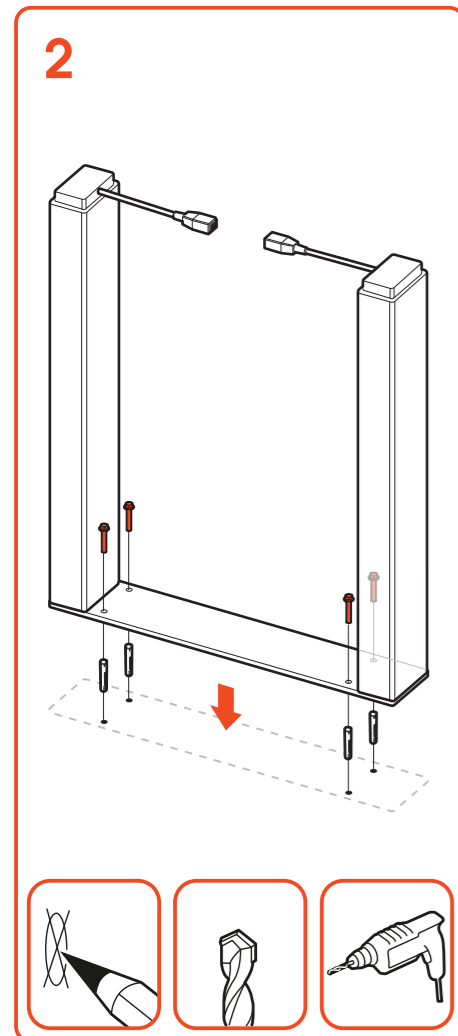
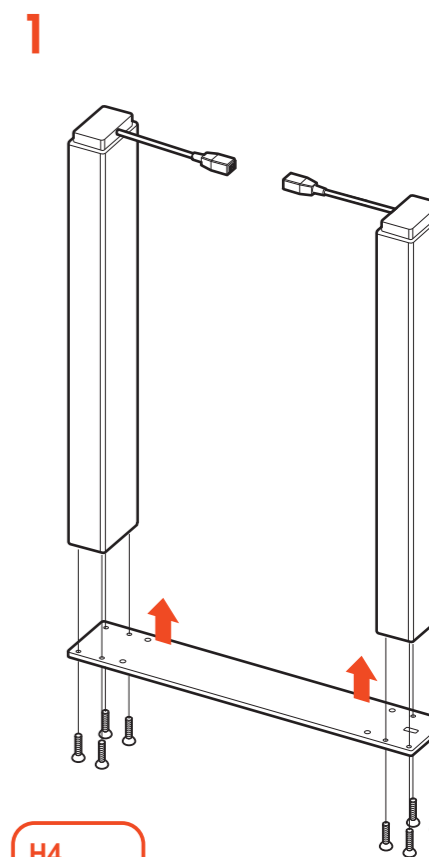

**EN. NOTE:** Anchors are not included, type of anchor needs to be determined on side. For selecting the right anchors, please contact your local specialist. For example: Fischer at: <https://www.fischer-international.com/en>.

**DE. HINWEIS:** Die Dübel sind nicht enthalten, der passende Dübel muss vor Ort ermittelt werden. Bitte wenden Sie sich an Ihren Spezialisten vor Ort, um den richtigen Dübel auszuwählen. Zum Beispiel: Fischer unter: <https://www.fischer-international.com/en>.

**FR. REMARQUE :** Les fixations ne sont pas fournies, le modèle des fixations devant être déterminé à part. Veuillez contacter votre spécialiste local pour la sélection des fixations qui conviennent. Par exemple : Fischer à :<https://www.fischer-international.com/en>.

**NL. LET OP:** Verankeringen niet inbegrepen. Het type verankering dient ter plaatse te worden bepaald. Neem voor het kiezen van de juiste ankers contact op met je lokale specialist. Bijvoorbeeld Fischer:<https://www.fischer-international.com/en>.

**ES. NOTA:** No se incluyen los anclajes. El tipo de anclaje debe determinarse según la ubicación. Para seleccionar los anclajes correctos, contacta con tu especialista local. Por ejemplo: Fischer en: <https://www.fischer-international.com/en>.

**IT. NOTA:** gli ancoraggi non sono inclusi, il tipo di ancoraggio deve essere determinato separatamente. Contattare uno specialista locale per selezionare gli ancoraggi adatti. Ad esempio: Fischer all'indirizzo: <https://www.fischer-international.com/en>.

**RUS. ВНИМАНИЕ!** Дюбели в комплект не входят. Тип дюбелей определяется по месту установки. Для выбора подходящих дюбелей, пожалуйста, обратитесь к специалисту. Например, сайт Fischer: <https://www.fischer-international.com/en>.

**PL. UWAGA:** Zestaw nie zawiera śrub kotwowych. Rodzaj potrzebnych śrub należy określić na miejscu montażu. Skontaktuj się z lokalnym specjalistą, aby otrzymać pomoc przy wyborze właściwych śrub. Na przykład: Fischer na: <https://www.fischer-international.com/en>

(GB) Subject to printing errors and technical amendments.  
(NL) Drukfouten en technische wijzigingen voorbehouden.  
(F) Sous réserve de fautes d'impression et de modifications techniques.  
(D) Für Druckfehler übernehmen wir keine Verantwortung. Technische Änderungen vorbehalten.  
(E) Reservados errores de imprenta y sujete a modificaciones.  
(I) Con riserva di modifiche tecniche e di eventuali errori di stampa.  
(P) Reserva-se a ocorrência de gralhas e de modificações técnicas.  
(H) Nyomdahibák és technikai változtatások joga fenntartva.  
(PL) Zastrzega się możliwość występowania błędów drukarskich i zmian technicznych.  
(RUS) Возможны ошибки при печати и технические модификации.

Designed and engineered in the Netherlands  
More information on: [www.vogels.com](http://www.vogels.com)

VOGEL'S PRODUCTS BV, HONDSRUGLAAN 93, 5628 DB EINDHOVEN, THE NETHERLANDS

## Before use / reset procedure

- 1 CHECK THE CONNECTION FROM THE REMOTE TO THE CONTROLBOX  
CHECK THE CONNECTION FROM THE POWER PLUG TO THE CONTROLBOX

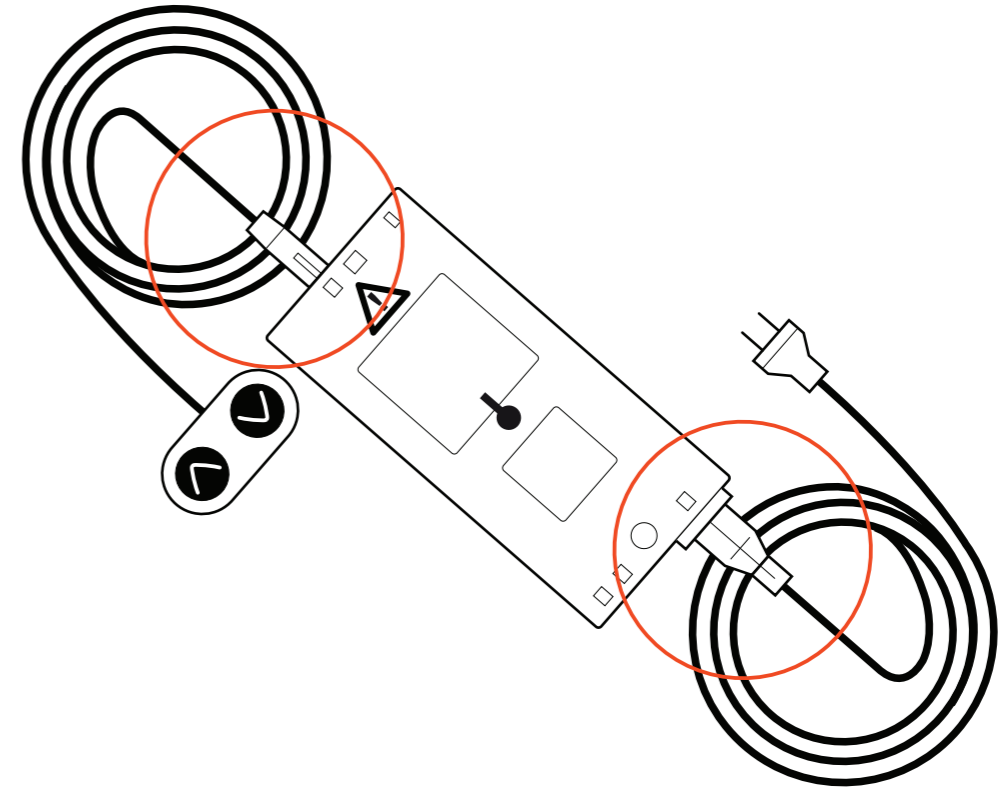

- 2 CONNECT THE POWER PLUG

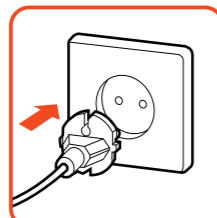
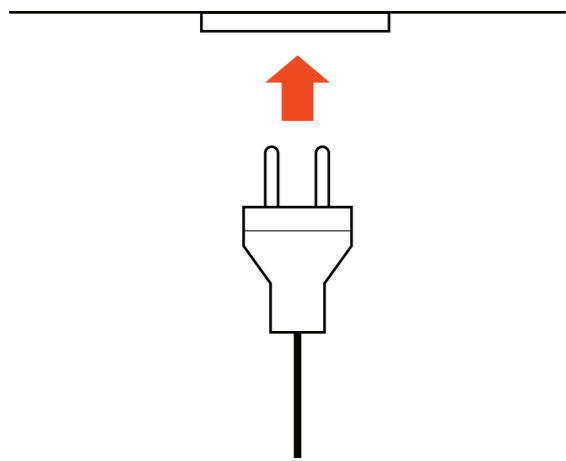

- 3 MOVE TO LOWEST POSITION

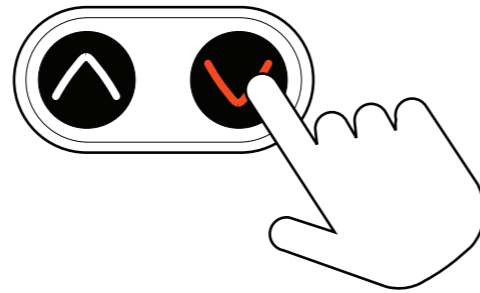

- 4 RELEASE THE DOWN BUTTON

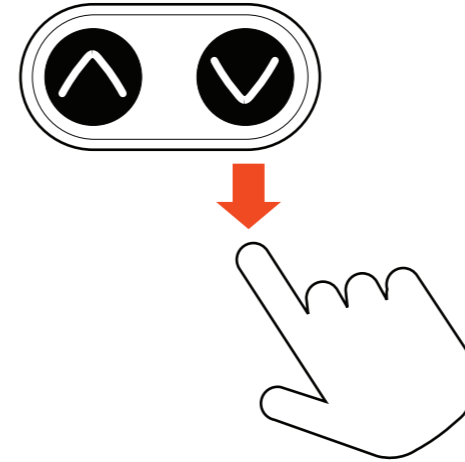

- 5 HOLD DOWN BUTTON FOR 30 SECONDS. PRODUCT IS INITIALIZED / RESET WHEN ACTUATOR QUICKLY GOES UP AND DOWN FOR 1 CM.

